

Case Study – Service Provider

Application: IVRS
Industry: Third Party IVR

Dialnet - A Profile

Dialnet Communications is the largest third party service providers for IVR facilities in India. It provides third party IVR to a host of clients like UTI, United breweries, Coca Cola, Airtel among others. Dialnet is also India's largest public Voice Mail Service provider. They run a variety of services like Vibezone, Jukebox targeted at college going and office professionals.

Dialnet has been given a level DID which has 10000 virtual numbers. Their level DID numbers are from 9390000 to 9399999.

All their services are run on the Level DID based applications.

Dialnet - Requirements

Dialnet needed an application that allowed quick and easy roll out of IVRS at a short notice. The resident team of Software engineers would develop the IVRS as per the client requirements.

This Application would also provide hosting multiple applications like Voice Mail Jukebox etc. simultaneously on one platform.

MARS CT Server

Dialnet implemented MARS CT server for development of Voice Mail and IVRS.

MARS CT Server is a real time Telephony Resource Application Server based on WIN NT for developing Computer Telephony applications like Voice Mail, Call Center, Prepaid Solutions etc. The real-time Telephony functions of the MARS CT server are based on Dialogic Telephony Cards.

MARS is configured to handle Analog, E-11 R2MFC, ISDN PRI and SS# 7 connectivity.

Features:

LAN	TCP/IP & Novel
Database	Oracle
Database Server	Oracle
Number of CO Lines	6 X E-1 R2MFC
Call Handling	Through MARS CT Server
Call Type	Incoming, Outgoing
Services	Multiple
Peak load	100,000 calls
No. of calls handled on average (daily)	Voice & Fax Mail : 1406.217 (5 .13 lakhs calls) INS POLL : 1237.299 (4.5 lakhs calls) Cricket Online: 2,90,000 calls for about 100 matches covered.

Dialnet
IVR Applications

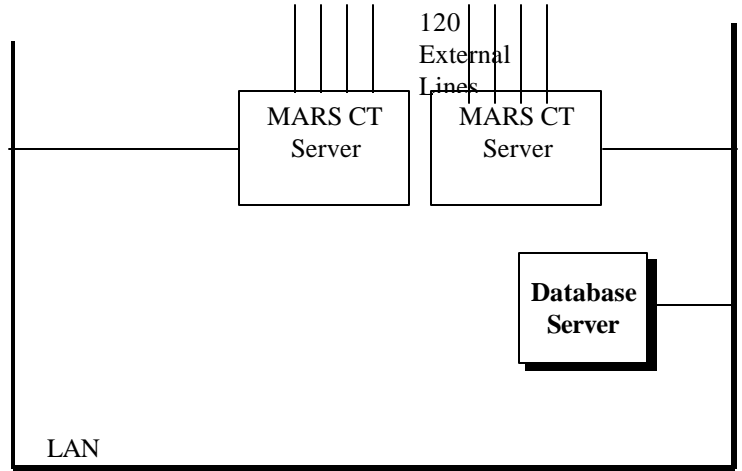

Functionality

- **Multilingual Capabilities:** The system can respond depending on the caller's preference.
- **Automated Interactive Voice Response Services** for inquiries on marketing information, recording complaints and claim inquiries.
- **Fax-on-Demand services** for information on various schemes and various forms.
- **Conferencing Capabilities** to provide applications like Business Conferences, Chat solutions.
- **Call servicing** depending on DNIS digits, IVR selections, or CLI.
- **Call details** including statistics on call lengths, options selected by users, and wait time entered in a standard database.

Dialnet- Applications

The various services hosted by Dialnet are as under:

- **TeleConnect Voice MAIL:** Dialnet has over 400 subscribers to this service. Callers can leave their messages for subscribers on their individual Voice Mail numbers. The Voice mailboxes are rented at a nominal charge.
- **UTI Dividend Announcement scheme** behind 9390064 (English) & 939 1064 (Hindi). Fully automated 24-hour service wherein a US64 holder has to dial in the certificate number to know the current status viz. a viz. their dividend for the financial year.
- **Cricket on Line** 939 0100. A fully automated on line cricket score and other field details on phone. This service is currently being provided for all one-day matches involving India and any other country. 10000+ callers dial into the service per day during any ongoing match.
- **Times of India Lok Sabha Pre-election Opinion Poll** behind 939 0198 (English), and 9390298 (Hindi). A dial in opinion poll with different topics every week to trace the trends and the mood of the electorate before the general elections.
- **TWI - Kingfisher Dial in contest** during the world cup soccer. This contest invited viewers during the match to guess the winner country and win fabulous prizes. More than 15000 callers dialed in per contest.

Benefits Realized

- **Lowered Costs of operation.** MARS CT Server is a single vendor system with local support lowering the IVR development costs and quick turnaround time.
- **The quick and easy development of IVRS** increases the flexibility and ability of Dialnet to host multiple IVRS for both long term and short term campaigns.

Planned Enhancements

- **Scale up solution** to 500 telephony ports
- **Expand to 5 major metros.**

Contact Information

For more information, contact:

Parsec Technologies (India) Ltd.
353, Udyog Vihar Phase II,
Gurgaon - 122016,
India
Telephone: +91-124-6343686/685
Fax: +91-124-6347547
Email: sales@parsec.co.in